

CAROL A CARTER RECITAL HALL

Flat Veneered Panels

Rulon manufactures Veneered Panels in several configurations which provide design solutions for architectural walls and ceilings. A variety of wood veneers, both domestic and exotic, give the architect virtually unlimited design freedom. Our manufacturing expertise allows us to provide either flat or curved panels, finished with a factory applied clear or custom stain finish.

Fire Retardancy

Veneered panels can be manufactured to meet ASTM E-84 Class 1 or A fire retardancy.





Factory-Applied Finishes

Veneered panels receive custom stains, clear sealers or color treatments which create a high-quality, durable, attractive finish. Finishes are water-based, contain no solvents and emit no VOC's.

Wood Selections

Veneered panels are supplied in a wide variety of natural or reconstituted wood veneers or HPL laminates. Some standard veneer species selections are:

- Cherry
- Maple
- Anegre
- Beech
- Ash
- Mahogany
- Bamboo
- Oak

** many other veneer species are available upon request!*

Installation

Installation methods for veneered panels may vary depending on panel style.

- Lay-In panels for heavy duty T-Bar
- Tegular edge panels for heavy duty T-Bar grid
- C-Hanger suspension system for heavy duty T-Bar grid
- Torsion Spring and Saddle Clip suspension into heavy duty T-Bar grid
- Z-Clips
- Direct screw attachment to heavy duty T-Bar grid or aircraft cable

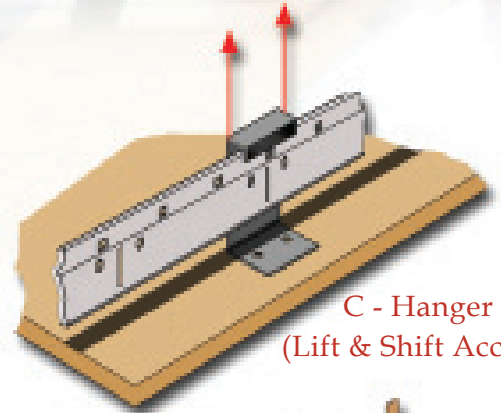

C - Hanger
(Lift & Shift Access)

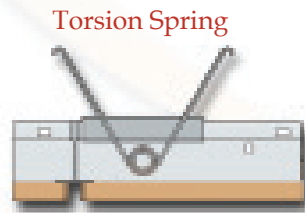

Torsion Spring

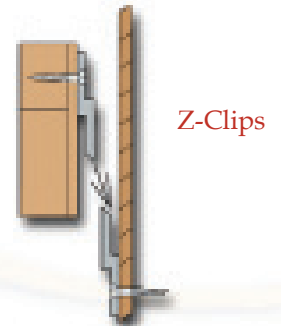

Z-Clips

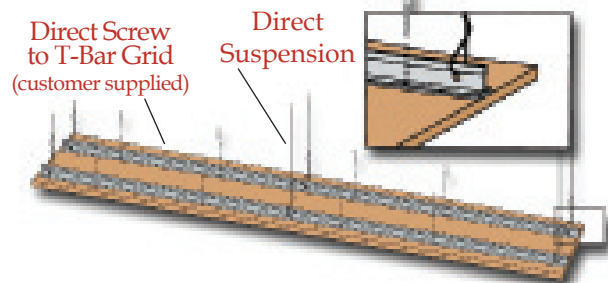

Direct Screw
to T-Bar Grid
(customer supplied)

Direct
Suspension

